

SANY

SCC1000TB

• Max. working radius
Main Boom 1.1t @ 48m

• Max. Lifting
Capacity: 100t @ 3.0m



The Sany SCC1000TB built with advanced safety features smart integrated Load Moment Indicator (LMI), assembly/working mode switch, emergency stop, over-hoist protection of the main/auxiliary load hoist, safety limit area protection. Consider the possibilities...

SPECIFICATIONS

SCC1000TB

DIMENSIONS

Length	16230mm
Width 3490mm (retracted)	5250mm (extended)
Height	3630mm
Weight	105t

CAPACITY

Max. capacity	100.0t @ 3m
Max. working radius (main boom)	1.1t @ 48m radius
Max. working radius (fly jib)	0.5t @ 56.5m
Max. Boom height (main boom)	59.0m
Max. Fly Jib height (fly jib)	76.5m

TRACK

Width	850mm
-------	-------

MIN. TRANSPORT

Max weight of single piece Transportation (remove main and Aux hook) including tracks	65.5t
Transportation dimensions (LxWxH)mm	16230 x 3000 3300 (tracks off)

WORKING RANGE

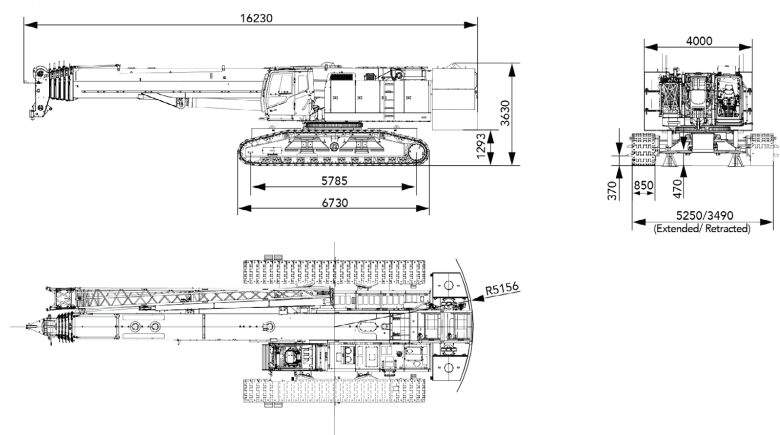
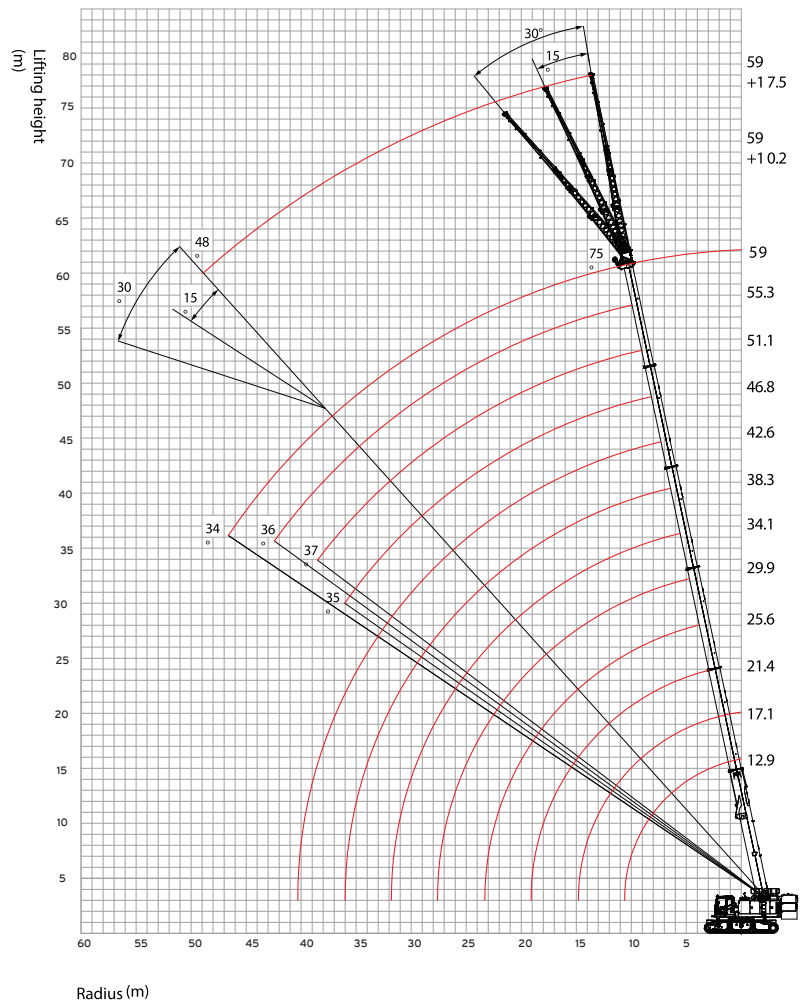

BOOM LOAD CHART

SCC1000TB

STB1000T6 Telescopic Crawler Crane-H

Rear counterweight 32t, Carbody counterweight:6t, track gauge:4.4m (gradient:0°)

Radius(m)	12.9	17.1	21.4	25.6	29.9	34.1	38.3	42.6	46.8	51.1	55.3	59	Radius(m)
3	100	82.5											3
3.5	86	79											3.5
4	82	77	71										4
4.5	78	76	69										4.5
5	73	71	67	66									5
6	63	62	60	56.3									6
7	50.4	50.6	50.4	46.9	45.4								7
8	40.6	40.8	41.4	40	39	38.2							8
9	33.7	33.9	34.4	33.9	34	33.5	29						9
10		28.7	29.3	28.7	29.5	29.7	26.5	25.4					10
12		21.5	22.1	21.6	22.3	23	22.9	21.9	20.6	20.5			12
14			17.3	16.9	17.5	18.2	18.1	17.7	17.7	17.6	16.4	13.5	14
16			14	13.5	14.1	14.8	14.7	14.3	14.5	14.8	14.9	12.5	16
18				11	11.6	12.3	12.2	11.8	12	12.2	12.6	11.5	18
20					9.7	10.3	10.2	9.9	10	10.3	10.6	10.6	20
22					8.1	8.7	8.6	8.3	8.4	8.7	9	9.1	22
24						7.4	7.3	7	7.1	7.4	7.7	7.8	24
26						6.4	6.3	5.9	6.1	6.3	6.7	6.7	26
28							5.4	5	5.2	5.4	5.8	5.8	28
30							4.6	4.3	4.4	4.7	5	5	30
32								3.6	3.7	4	4.3	4.4	32
34								3	3.2	3.4	3.7	3.8	34
36									2.6	2.9	3.2	3.3	36
38									2.2	2.4	2.8	2.8	38
40										2	2.4	2.4	40
42											2	2	42
44											1.7	1.7	44
46												1.4	46
48												1.1	48
Min. limit angle	0°	0°	0°	0°	0°	0°	0°	35°	34°	37°	36°	34°	Min. limit angle
II	0	0	46	46	46	46	46	46	46	92	92	100	II
III	0	46	46	46	46	46	46	46	46	92	92	100	III
IV	0	0	0	46	46	46	46	46	92	92	92	100	IV
V	0	0	0	0	46	46	46	92	92	92	92	100	V
VI	0	0	0	0	0	46	92	92	92	46	92	100	VI
Parts of line	12	11	10	9	8	7	6	5	4	3	3	3	Parts of line



COUNT ON US

1800 440 550 | prestonhire.com.au

JIB CHART

SCC1000TB

STB1000T6 Telescopic Crawler Crane-FJ

Rear counterweight 32t, Carbody counterweight:6t, track gauge:4.4m (gradient:0°)

Boom angle (°)	Jib:10.2m			Jib:17.5m			Boom angle (°)
	0°	15°	30°	0°	15°	30°	
80	6.8	5.2	4.5	4.0	2.5	1.8	80
78	6.6	5.0	4.5	3.8	2.4	1.7	78
76	6.4	4.8	4.1	3.5	2.3	1.7	76
74	6.2	4.5	3.9	3.2	2.2	1.6	74
72	6.0	4.3	3.8	3.0	2.1	1.6	72
70	5.4	4.2	3.7	2.9	2.0	1.6	70
68	5.2	4.1	3.6	2.8	1.9	1.5	68
66	5.0	3.9	3.5	2.7	1.9	1.5	66
64	4.5	3.7	3.2	2.6	1.9	1.5	64
62	3.8	3.2	2.7	2.5	1.8	1.4	62
60	3.2	2.7	2.3	2.4	1.8	1.4	60
58	2.7	2.3	2.0	2.2	1.8	1.4	58
56	2.3	1.9	1.7	1.9	1.5	1.2	56
54	1.9	1.6	1.4	1.5	1.3	1.0	54
52	1.5	1.3	1.2	1.3	1.0	0.8	52
50	1.2	1.1	1.0	1.0	0.8	0.7	50
48	1.0	0.9	0.8	0.8	0.6	0.5	48
46	0.8	0.7	0.6	0.6			46
44	0.6	0.5					44
42	0.5						42

※ Note-Rate load of crane:

1. The crawler must be extended when lifting.
2. The rated capacity in the load charts are calculated when the crane is parking on firm ground (gradient is within 1°), and lifting the load slowly and steadily.
3. The rated capacity values in the load charts are obtained when the wind speed is lower than 9.8 m/s under 75% of tipping load.
4. All values in the load charts are valid for 360° slewing.
5. The rated load shall be no more than 10.5t when using upper boom point sheave. If the jib unfolds, the rated lifting capacity of boom is 1.5t less.
6. The rated capacity in the load charts include the weight of lifting hook, therefore, the actual rated capacity is the value after deducting the weight of lifting tools (such as hook, riggings and wire rope), from the rated load in the load charts.
7. The rated values above is just for full-up counterweight and flat ground, See the Operation Manual for the complete load charts .

SPECIFICATIONS SUPERCRAANE™

1000TB

Major Performance & Specifications of STB1000T6			
Specification		Unit	Parameter
Outline dimension	Full length of the whole crane	mm	16230
	Width of the whole machine (retracted)	mm	5250(3490)
	Height of the whole machine	mm	3630
	Center distance of driving and engaged wheels	mm	5785
	Width of track shoe	mm	850
H (main boom) configuration	Maximum rated lifting weight	t	100
	Main boom length	m	12.8~59
	Main boom angle	°	0~80
	Maximum rated lifting moment	t·m	378
FJ(fixed jib) configuration	Longest main boom + longest jib	m	59+17.5
	Included angle between main boom and jib	°	0°, 15°, 30°
Working speed	Main/aux. load hoist rope speed	m/min	0~130
	Time to fully boom up/down	s	80/110
	Time to fully extend/retract boom	s	480/480
	Slewing speed	rpm	0~1.6
	No-load traveling speed	km/h	0~1.65
Engine	Model	/	6HK1XKJC-01
	Rated power/speed	kW/rpm	212/2000
Wire rope	Diameter	mm	Φ22
Transportation parameters	Weight of the whole machine	t	105
	Maximum weight of single piece transportation	t	65.5t (remove main and aux. hook) including tracks
	Transportation dimension (long x width x height)	mm	16230×3000×3300
Other Parameters	Average ground bearing pressure	MPa	0.1
	Min. swing radius	mm	5156



SPECIALISED EQUIPMENT HIRE SOLUTIONS

Branch Locations

NSW/ACT

Unit 4, 4 Dupas Street,
Smithfield, NSW 2164
nswsales@prestonhire.com.au

NSW

56 Sandringham Place,
Thornton, NSW, 2322
nswsales@prestonhire.com.au

QLD

83 Parramatta Road,
Underwood, QLD 4119
qldsales@prestonhire.com.au

VIC/TAS

38 Sunline Dr,
Truganina, VIC 3029
vicsales@prestonhire.com.au

WA/NT

Unit 2,8 Hunt Street,
Malaga, WA 6090
wasales@prestonhire.com.au

SA

102 Cormack Road,
Wingfield, SA 5013
sasales@prestonhire.com.au

**Preston Hire available across Oceania*



COUNT ON US

1800 440 550 | prestonhire.com.au