



- Crane Capacity 2.98t x 2.5m
- 4 Fall / 2 Fall Hook Block
- Max. Lifting Height 12.52

- Lithium-ion Battery
- Continuous Operation While Charging

- Light Weight & Low Noise
- Minimal Charging Time



The fully electric-powered Maeda MC305CB mini crane with zero emission, without compromising on performance. Innovative lithium-ion batteries make these models environmentally friendly, economical, efficient, and safe. You can fully operate the crane while charging and short recharge time allows for a more continuous operation. Consider the possibilities...

SPECIFICATIONS

MAEDA MC305CB

DIMENSIONS

Length	4195mm
Width	750mm
Height	1695mm
Weight	3,925 kg

CAPACITY

Max. capacity Max.	2.98t x 2.5m
Max. working radius (main boom)	12.16m x 0.26t
Max. lifting height (main boom)	12.52m

BATTERY SYSTEM

5 hour rate capacity,
Lithium Titanate battery, DC55V-180Ah,
4.5 hour charge time

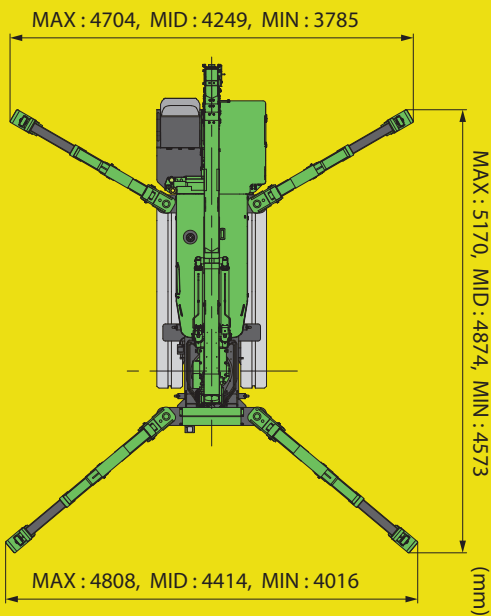

WORKING RANGE

MAX. Reach Below Ground

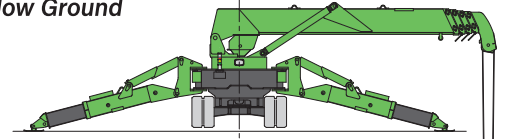

Working Range Chart (4falls)

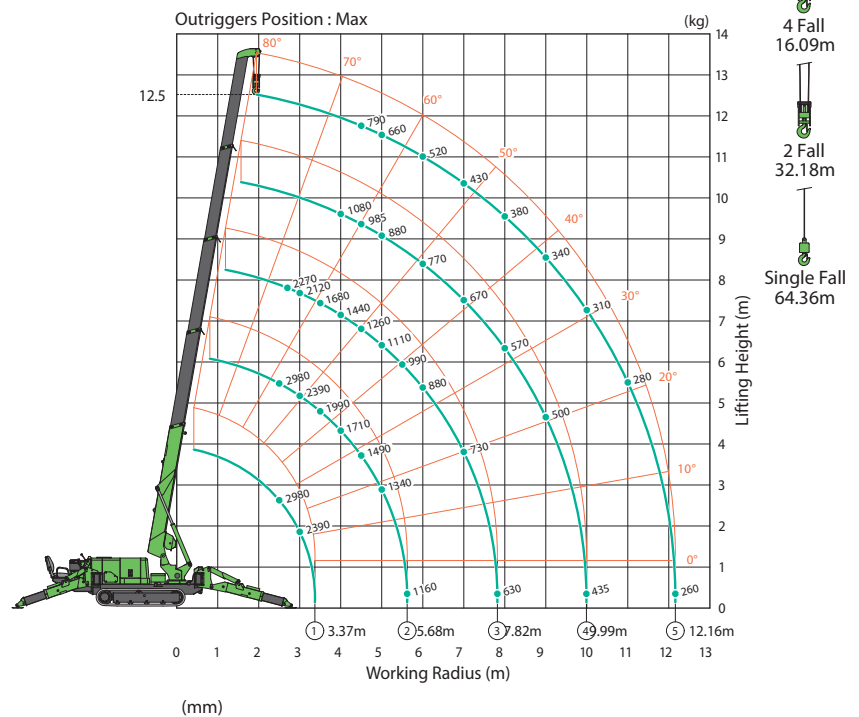

Dimensions

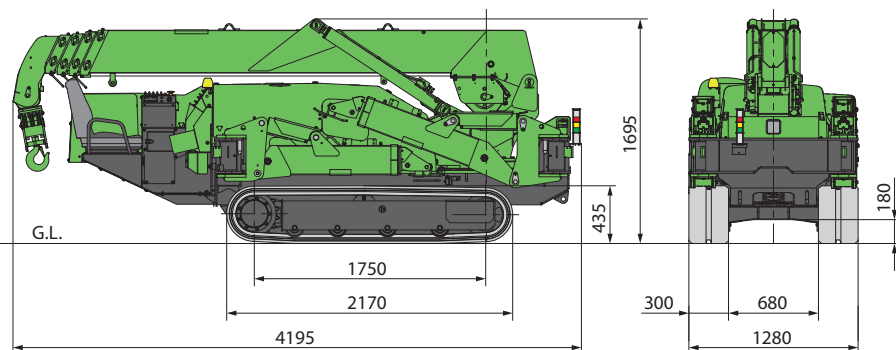

LOAD CHART

MAEDA MC305CB

OUTRIGGER EXTENDED TO MAXIMUM

3.695m / 5.945m Boom		8.145m Boom		10.315m Boom		12.485m Boom	
Working radius(m)	Rated total load(kg)	Working radius(m)	Rated total load(kg)	Working radius(m)	Rated total load(kg)	Working radius(m)	Rated total load(kg)
2.5 or less	2980	2.7	2270	4.0	1080	4.5 or less	790
3.0	2390	3.0	2120	4.5	985	5.0	660
3.5	1990	3.5	1680	5.0	880	6.0	520
4.0	1710	4.0	1440	6.0	770	7.0	430
4.5	1490	4.5	1260	7.0	670	8.0	380
5.0	1340	5.0	1110	8.0	570	9.0	340
5.62	1160	5.5	990	9.0	500	10.0	310
		6.0	880	9.99	435	11.0	280
		7.0	730			12.16	260
		7.82	630				

* The Rated Total Load Chart is based on actual working radius with the bending of boom attributable to load reflected and is shown with the mass of hook (30kg) included.

MODEL		MC305CRMB-3	
Crane capacity		2.98t x 2.5m	
Type		Lithium Titanate Battery	
Input Voltage / current		Single phase	
Battery system	Charging time	with AC-200V	80% : 3h00min / 100% : 4h30min
	Operating time	Travelling (Hi speed)	Up to 2h 50min
		Crane	Up to a full working day if charged during operation
	Charging during operation	Available	
Rated Output		Variable 7.5kW AC30V at 2500min ⁻¹	
Overall length x width x height		4,195mm x 1,280mm x 1,695mm	
Machine weight		3,925kg	
Safety device		Overwind protection, Load indicator, Hydraulic safety valve, Level, Inclination alarm, EMO switch, Travel lock lever, Outrigger interlock device, Moment limiter, Beacon	

Disclaimer : All information provided in this publication is correct at time of printing. Please contact Preston Hire for any updated versions.



COUNT ON US

1800 440 550 | prestonhire.com.au



SPECIALISED EQUIPMENT HIRE SOLUTIONS

Branch Locations

NSW/ACT

Unit 4, 4 Dupas Street,
Smithfield, NSW 2164
nswsales@prestonhire.com.au

NSW

56 Sandringham Place,
Thornton, NSW, 2322
nswsales@prestonhire.com.au

QLD

83 Parramatta Road,
Underwood, QLD 4119
qldsales@prestonhire.com.au

VIC/TAS

38 Sunline Dr,
Truganina, VIC 3029
vicsales@prestonhire.com.au

WA/NT

Unit 2,8 Hunt Street,
Malaga, WA 6090
wasales@prestonhire.com.au

SA

102 Cormack Road,
Wingfield, SA 5013
sasales@prestonhire.com.au

**Preston Hire available across Oceania*



COUNT ON US

1800 440 550 | prestonhire.com.au