



- Crane Capacity 2.82t x 1.4m
- 4 Fall / 2 Fall Hook Block
- Max. Lifting Height 8.7m

- Lithium-ion Battery
- Continuous Operation While Charging

• Max working radius 8.205m x 0.15t



The fully electric-powered Preston Hire Maeda MC285CB mini crane with zero emission, without compromising on performance. Innovative lithium-ion batteries make these models environmentally friendly, economical, efficient, and safe. You can fully operate the crane while charging and short recharge time allows for a more continuous operation. Consider the possibilities...

SPECIFICATIONS

MAEDA MC285CB

DIMENSIONS

Length	2800mm
Width	750mm
Height	1740mm
Weight	1995kg

CAPACITY

Max. capacity Max.	2820kg at 1.4m
Max. working radius (main boom)	8.205m x 0.15t
Max. working radius (fly jib)	N/A
Max. lifting height (main boom)	8.7m
Max. lifting height (fly jib)	N/A

BATTERY

Type	Lithium Titanate Battery
Charging time (with AC-200V)	80% : 2h 20min /100% : 3h 30min
Charging time (with AC-200V)	80% : 5h 20min /100% : 7h 00min

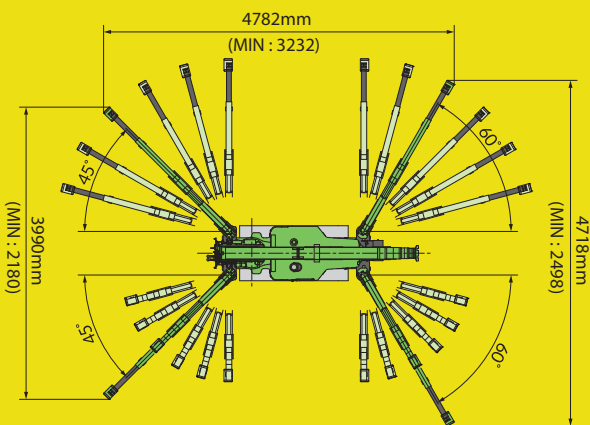

* Due to improvements, the specifications are subject to change without notice.

WORKING RANGE

Max. Reach Below Ground

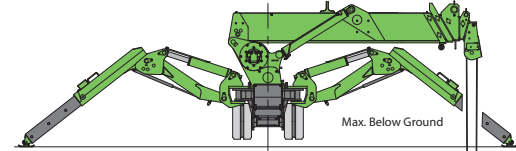

Working Range Chart (4 falls)

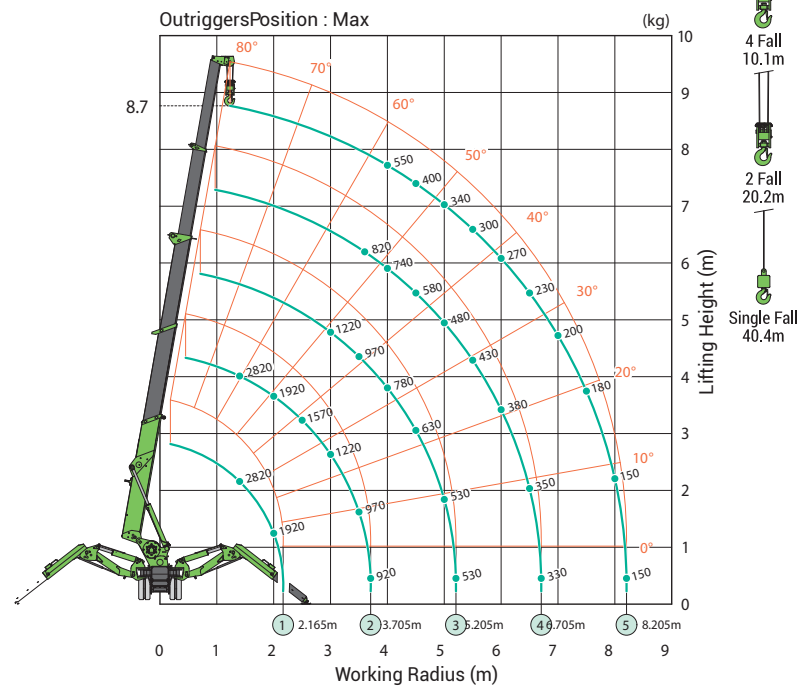

Dimensions

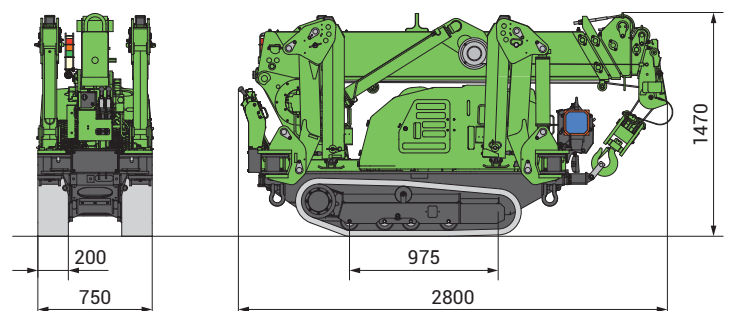

LOAD CHART

MAEDA MC285CB

LOAD CHART

OUTRIGGER EXTENDED TO MAXIMUM

2.535m / 4.075m Boom		5.575m Boom		7.075m Boom		8.575m Boom	
Working radius(m)	Rated total load(kg)	Working radius(m)	Rated total load(kg)	Working radius(m)	Rated total load(kg)	Working radius(m)	Rated total load(kg)
1.4 or less	2820	3.0 or less	1220	3.6 or less	820	4.0 or less	550
1.5	2520	3.5	970	4.0	740	4.5	400
2.0	1920	4.0	780	4.5	580	5.0	340
2.5	1570	4.5	630	5.0	480	5.5	300
3.0	1220	5.0	530	5.5	430	6.0	270
3.5	970	5.205	530	6.0	380	6.5	230
3.705	920			6.5	350	7.0	200
				6.705	330	7.5	180
						8.0	150
						8.205	150

OUTRIGGER AT SECONDARY POSITION

2.535m / 4.075m Boom		5.575m Boom		7.075m Boom		8.575m Boom	
Working radius(m)	Rated total load(kg)	Working radius(m)	Rated total load(kg)	Working radius(m)	Rated total load(kg)	Working radius(m)	Rated total load(kg)
1.5 or less	1720	3.0 or less	510	3.6 or less	400	4.0 or less	330
2.0	1070	3.5	410	4.0	330	4.5	280
2.5	630	4.0	330	4.5	280	5.0	230
3.0	520	4.5	280	5.0	230	5.5	180
3.5	390	5.0	200	5.5	180	6.0	160
3.705	350	5.205	200	6.0	160	6.5	130
				6.5	130	7.0	100
				6.705	120	7.5	80
						8.0	70
						8.205	60

* The Rated Total Load Chart is based on actual working radius including boom deflection.

* The weight of hook block (standard 4 fall / 2 fall-30kg) must be included as part of the load shown in the Rated Total Load Chart.

* When using two falls hook or single fall hook, use the appropriate four falls Rated Total Load Chart shown above but with a maximum load of : -1410kg for two falls and -710kg for Single fall.

The total rated load charts are based on the actual working radius including boom deflection.

Disclaimer : All information provided in this publication is correct at time of printing. Please contact Preston Hire for any updated versions.



SPECIALISED EQUIPMENT HIRE SOLUTIONS

Branch Locations

NSW/ACT

Unit 4, 4 Dupas Street,
Smithfield, NSW 2164
nswsales@prestonhire.com.au

NSW

56 Sandringham Place,
Thornton, NSW, 2322
nswsales@prestonhire.com.au

QLD

83 Parramatta Road,
Underwood, QLD 4119
qldsales@prestonhire.com.au

VIC/TAS

38 Sunline Dr,
Truganina, VIC 3029
vicsales@prestonhire.com.au

WA/NT

Unit 2,8 Hunt Street,
Malaga, WA 6090
wasales@prestonhire.com.au

SA

102 Cormack Road,
Wingfield, SA 5013
sasales@prestonhire.com.au

**Preston Hire available across Oceania*



COUNT ON US