

The Blulift 16.74 is perfect for two man jobs at maximum reach and maximum height.

With a maximum 16m working height and 7.4m outreach, this is the first true two man basket with a full working envelope at 230kg.

The new addition handles 28% gradeability and features a hydraulic levelling system with closed circuit and self-stabilising system for a smooth ride, plus a quickly removeable aluminium basket.

SPECIFICATIONS

BLUELIFT 16.74

SPECIFICATIONS

Working height, max.	15,8 m
Horizontal outreach, max	7,4 m/230 kg
Basket capacity	230 kg
Basket dimension	1,3m x 0,7m x 1,1m
Turret rotation	340°
Overall weight	2100kg
Travel speed	1,5 km/h
Gradeability, max.	28%
Combustion engine	HATZ Diesel
Electric motor	Lithium Battery

STANDARD EQUIPMENT

- Quickly removable aluminum basket
- Basket rotation
- i-Performing electric pump (patented) with auto Start/Stop system
- 240V power outlet in basket
- Cable remote control with interactive and multi-lingual display
- Load limiting device
- Automatic center position of turret
- Self Stabilizing system
- Automatic START & STOP of engines and RPM control
- Proportional and simultaneous electro-hydraulic controls
- Proportional track drive with hydraulic breaking system
- Driving Lateral slope alarm with safety stop
- Driving possible with jib boom raised (with selector)
- Interblock outriggers/booms
- Emergency push-button with engine stop
- Hand pump for the emergency lowering of platform
- Modem connection plug for diagnosis/software upgrading in remote
- Radio remote control
- Diesel engine
- Blue Lithium pack
- Track width adjusting system
- Double drive speed system with safety control
- Go-Home function

WEIGHT DISPERSIONS

Load on each footplate:

KG	KN
1428 kg	14,00kN

Load on tracks:

Area Under Tracks	Weight Machine	PSI
572,88 sq in	2100kg	7,69 psi

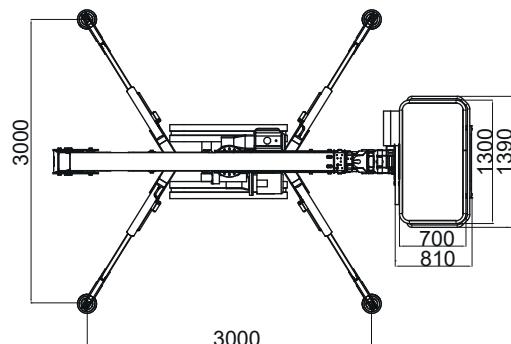
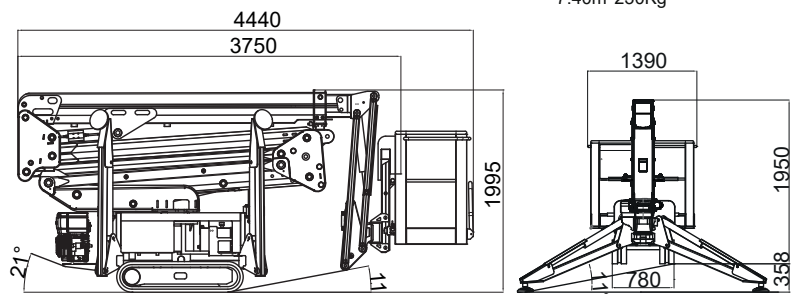
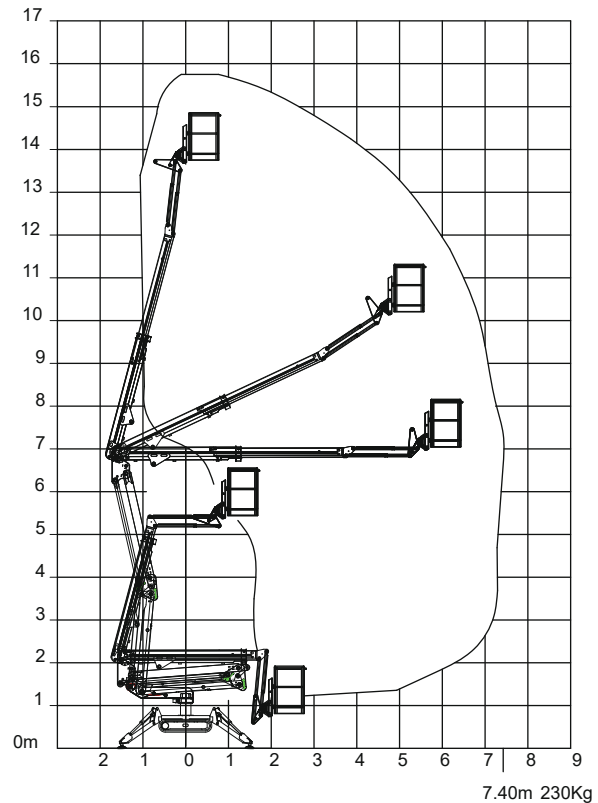



SPECIALISED EQUIPMENT HIRE SOLUTIONS

Branch Locations

NSW/ACT

Unit 4, 4 Dupas Street,
Smithfield, NSW 2164
nswsales@prestonhire.com.au

NSW

56 Sandringham Place,
Thornton, NSW, 2322
nswsales@prestonhire.com.au

QLD

83 Parramatta Road,
Underwood, QLD 4119
qldsales@prestonhire.com.au

VIC/TAS

38 Sunline Dr,
Truganina, VIC 3029
vicsales@prestonhire.com.au

WA/NT

Unit 2,8 Hunt Street,
Malaga, WA 6090
wasales@prestonhire.com.au

SA

102 Cormack Road,
Wingfield, SA 5013
sasales@prestonhire.com.au

**Preston Hire available across Oceania*



COUNT ON US

1800 440 550 | prestonhire.com.au