

• Yanmar 4TNV98CT-VSY Engine



• 8800kg Operating Mass

The SANY SY80U is tailored to the requirements of tough everyday use on the construction site. It demonstrates its impressive versatility when digging and loading. Its agility is evident, thanks to its swivelling boom and zero tail swing. Aside from the compact design, it impresses with first class performance, low fuel consumption and outstanding user comfort. The driver's seat with high backrest offers the operator a comfortable workplace, thereby reducing symptoms of fatigue. The positioning of the controls is ergonomically designed - clear and easy to reach, they help to ensure that the operator can achieve maximum productivity while working

SPECIFICATIONS

SANY SY80U

ENGINE

| | |
|-------------------|---|
| Modell | YANMAR 4TNV98CT-VSY |
| Typ | Water-cooled, 4 cylinder, with commonrail and DPF |
| Exhaust emissions | Stage V |
| Rated power | 53.7 kW / 2 100 rpm |
| Max. torque | 290 Nm / 1 350 rpm |
| Displacement | 3 318 ccm |
| Batteries | 1 × 12 V / 120 Ah |

HYDRAULIC SYSTEM

| | |
|----------------------|---|
| Mainpump | variable-piston-pump; Load sensing control |
| Max. oilflow | 193.2 l/min |
| Travelmotor | Variable displacement axial piston motor |
| Swingmotor | Axial piston motor |
| Max. oilflow (AUX 1) | 100 l/min |
| Max. oilflow (AUX 2) | 70 l/min |

SERVICE REFILL CAPACITIES

| | |
|--------------------|--------|
| Fuel tank | 100 l |
| Engine coolant | 12 l |
| Engine oil | 10,2 l |
| Drive (per side) | 1,2 l |
| Hydraulic system | 160 l |
| Hydraulic oil tank | 120 l |

PERFORMANCE

| | |
|--------------------------|------------------------------|
| Swingspeed | 10 rpm |
| Max. travel speed | High 4.5 km/h, slow 2.5 km/h |
| Max. travel force | 70 kN |
| Gradeability | 35° |
| Bucket capacity | 0.28 m ³ |
| Groundpressure | 0.38 kg/cm ² |
| Bucket digging force ISO | 72.7 kN |
| Arm digging force ISO | 40.5 kN |

RELIEF VALVE SETTINGS

| | |
|-------------------|---------|
| Implement circuit | 280 bar |
| Swing circuit | 215 bar |
| Travel circuit | 280 bar |
| Pilot pressure | 35 bar |

UNDER AND UPPER STRUCTURE

| | |
|-----------------|--|
| Boom length | 3 520 mm |
| Arm length | 2 050 mm |
| Bottomrollers | 4 |
| Toprollers | 1 |
| Rotation device | Planetary gear reducer driven by an axial piston motor, automatic hydraulic released slewing brake |

OPERATING MASS

SY80U 8 800 kg

LIFTING CAPACITIES - DOZER BLADE DOWN

| Load point height | Radius | | | | | | Digging reach | | | |
|-------------------|--------|------|-------|------|-------|------|---------------|------|------|----|
| | 3.0 m | | 4.0 m | | 5.0 m | | Max. | | | |
| 5.0 m kg | | | | | | | | | | mm |
| 4.0 m kg | 1960 | 1960 | 1800 | 1338 | 1710 | 1325 | 5025 | | | |
| 3.0 m kg | 2080 | 2080 | 2085 | 1345 | 1225 | 1055 | 5703 | | | |
| 2.0 m kg | 3100 | 3100 | 2540 | 1875 | 2275 | 1315 | 1585 | 930 | 6106 | |
| 1.0 m kg | 4745 | 2675 | 3180 | 1760 | 2570 | 1260 | 1630 | 865 | 6297 | |
| Ground line kg | 4325 | 2450 | 3745 | 1650 | 2845 | 1205 | 1750 | 855 | 6297 | |
| -1.0 m kg | 4850 | 2390 | 4020 | 1590 | 2995 | 1170 | 1965 | 885 | 6109 | |
| -2.0 m kg | 5670 | 2360 | 3950 | 1550 | 2935 | 1140 | 2370 | 995 | 5707 | |
| -3.0 m kg | 4915 | 2375 | 3490 | 1550 | 2445 | 1150 | 2400 | 1185 | 5031 | |
| | 3385 | 2450 | | | | | 2290 | 1735 | 3899 | |

LIFTING CAPACITIES - DOZER BLADE UP

| Load point height | Radius | | | | | | Digging reach | | | |
|-------------------|--------|------|-------|------|-------|------|---------------|------|------|----|
| | 3.0 m | | 4.0 m | | 5.0 m | | Max. | | | |
| 5.0 m kg | | | | | | | | | | mm |
| 4.0 m kg | 1960 | 1960 | 1800 | 1338 | 1710 | 1325 | 5025 | | | |
| 3.0 m kg | 2080 | 2080 | 2085 | 1345 | 1225 | 1055 | 5703 | | | |
| 2.0 m kg | 3100 | 3100 | 2540 | 1875 | 1770 | 1315 | 1285 | 930 | 6106 | |
| 1.0 m kg | 3850 | 2675 | 2425 | 1760 | 1715 | 1260 | 1185 | 865 | 6297 | |
| Ground line kg | 3595 | 2450 | 2305 | 1650 | 1655 | 1205 | 1170 | 855 | 6297 | |
| -1.0 m kg | 3525 | 2390 | 2240 | 1590 | 1615 | 1170 | 1215 | 885 | 6109 | |
| -2.0 m kg | 3490 | 2360 | 2195 | 1550 | 1585 | 1140 | 1360 | 995 | 5707 | |
| -3.0 m kg | 3510 | 2375 | 1550 | 1550 | 1600 | 1150 | 1630 | 1185 | 5031 | |
| | 3385 | 2450 | | | | | 2290 | 1735 | 3899 | |

SPECIFICATIONS

SANY SY80U

DIMENSIONS (TRANSPORT)

| | | |
|---|------------------------------|---------|
| A | Transport length | 6500 mm |
| B | Transport width | 2220 mm |
| C | Upperstructure carriage | 2150 mm |
| D | Height over cabin/ROPS | 2550 mm |
| E | Height of Boom – transport | 2220 mm |
| F | Overall length of crawler | 2915 mm |
| G | Tail length | 1480 mm |
| H | Track gauge | 1750 mm |
| I | Undercarriage width (blade) | 2200 mm |
| J | Horizontal distance to blade | 2080 mm |
| K | Blade height | 2080 mm |
| L | Track height | 660 mm |
| M | Track pads width | 450 mm |
| N | Min. ground clearance | 365 mm |
| O | Counterweight clearance | 745 mm |
| P | Engine cover height | 1880 mm |
| Q | Tail swing radius | 1480 mm |
| R | Center distance of tumbler | 2315 mm |

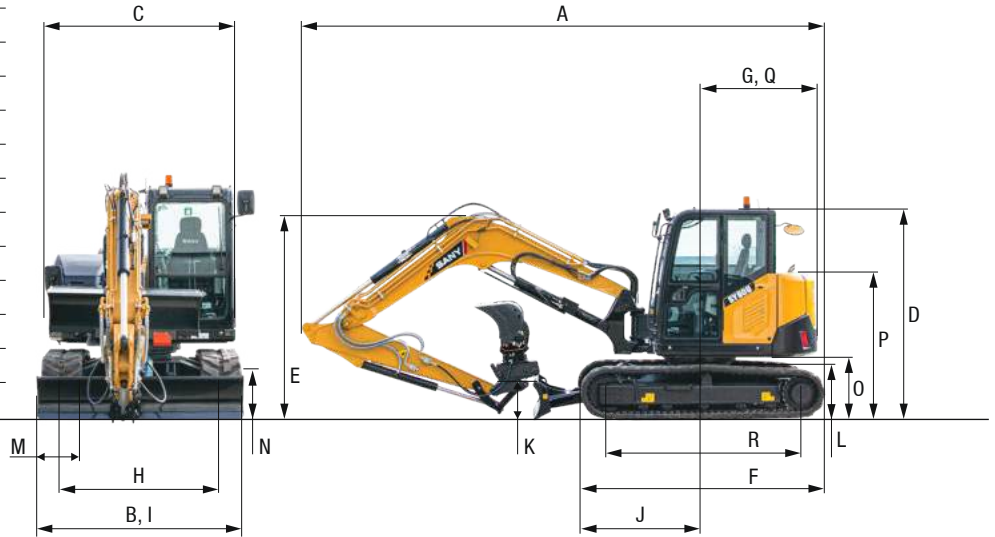

WORKING AREA

| | | |
|---|--|---------|
| A | Max. digging reach | 7290 mm |
| B | Max. digging depth | 4535 mm |
| C | Max. digging height | 7315 mm |
| D | Max. dumping height | 5430 mm |
| E | Min. dumping height | 1915 mm |
| F | Max. vertical digging depth | 2490 mm |
| G | Overall height over arm by min. swing radius | 5490 mm |
| H | Arm head distance with work equipment retracted as far as possible | 2080 mm |
| I | Swing radius by max. boomswing (L) | 4510 mm |
| | Swing radius by max. boomswing (R) | 4670 mm |
| | Min. swing radius | 2435 mm |
| J | Max. clearance when blade up | 480 mm |
| K | Max. depth of blade down | 325 mm |
| L | Offset boom (L) | 636 mm |
| | Offset boom (R) | 740 mm |
| | Max. boom-swing angle (L) | 65° |
| | Max. boom-swing angle (R) | 51° |

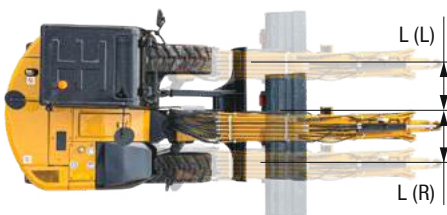
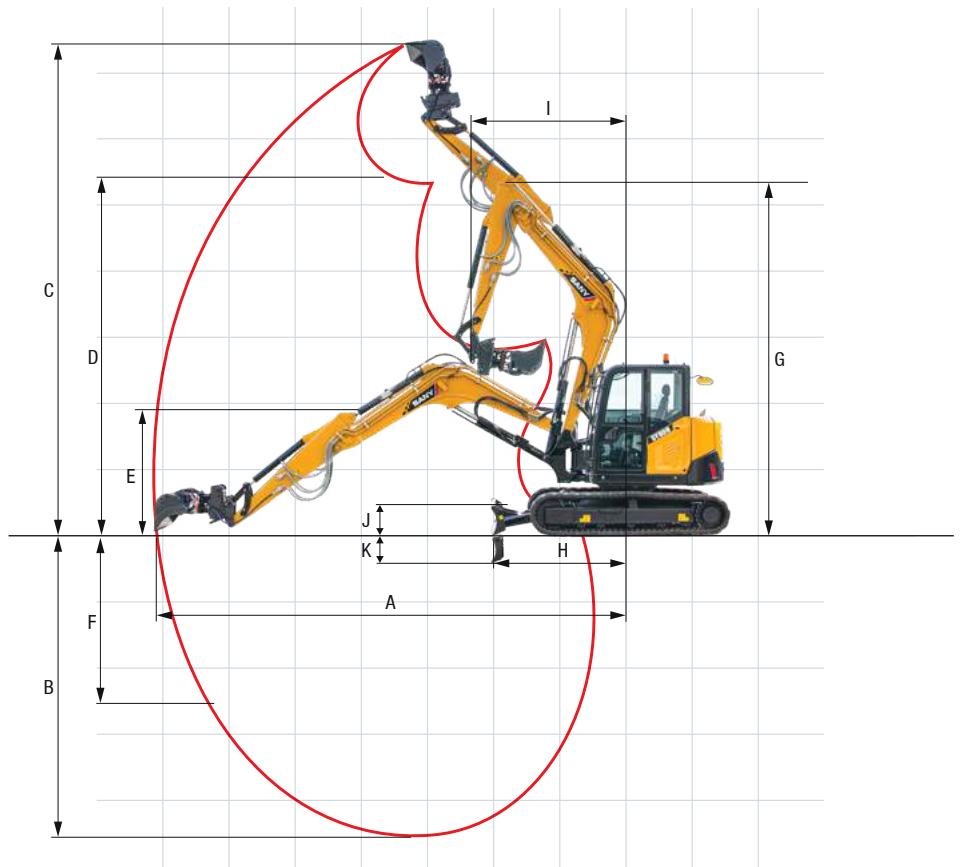



SPECIALISED EQUIPMENT HIRE SOLUTIONS



Branch Locations

NSW/ACT

25-39 Chadderton Street,
Cabramatta NSW 2166
nswsales@prestonhire.com.au

NSW

56 Sandringham Place,
Thornton, NSW, 2322
nswsales@prestonhire.com.au

QLD

83 Parramatta Road,
Underwood, QLD 4119
qldsales@prestonhire.com.au

VIC/TAS

38 Sunline Dr,
Truganina, VIC 3029
vicsales@prestonhire.com.au

WA/NT

Unit 2,8 Hunt Street,
Malaga, WA 6090
wasales@prestonhire.com.au

SA

102 Cormack Road,
Wingfield, SA 5013
sasales@prestonhire.com.au

**Preston Hire available across Oceania*



COUNT ON US

1800 440 550 | prestonhire.com.au