



# SANY SY215C



21900kg Operating  
Weight

Mitsubishi 6D34-TL Engine

The SANY SY215C is a powerful all-rounder which combines flexibility and power. It can therefore perform various tasks in a wide range of applications and its robust design means that it is comfortable even with difficult tasks in tough environments. For operators to fully concentrate on their work, they first need to be sitting comfortably. The individually adjustable, air-suspension seat offers a comfortable workstation and the multifunctional control levers are located within easy reach. This makes it possible to reliably and precisely control the auxiliary attachments, directly relaying the control commands without delay



COUNT ON US

1800 440 550 | [prestonhire.com.au](http://prestonhire.com.au)

# SPECIFICATIONS

# SANY SY215C

## OVERALL DIMENSIONS

A	Transport Length	9680 mm
B	Transport Width	2980 mm
C	Transport Height	3440 mm
D	Upper Width	2875 mm
F	Cab Height	3075 mm
G	Tail Swing Radius	2900 mm
H	Min. Ground Clearance	440 mm

## WORKING RANGE

a	Maximum Digging Height	9600 mm
b	Maximum Dumping Height	6730 mm
c	Maximum Digging Depth	6600 mm
d	Maximum Vertical Digging Depth	6255 mm
e	Maximum Digging Reach	10280 mm
f	Maximum Swing Radius	3730 mm
g	Height at Min. Swing Radius	7680 mm

## MACHINE PARAMETERS

Operating Weight	21900 kg
Engine Type	Mitsubishi 6D34-TL
Engine Max Power (Gross)	114/ 2050 kW/ rpm
Engine Max Torque	590/ 1400 N m/ rpm
Engine Displacement	5.86L
Emission Standard	Tier 2
Swing Speed	11rpm
Travel Speed	5.4/ 3.3km/ h
Fuel Tank Capacity	340 L
Hydraulic Tank Capacity	239 L
Engine Oil Capacity	22 L
Ground Pressure	47.4kPa
Gradeability	70%/ 35°
Bucket Digging Force	138kN
Arm Digging Force	103kN
Tractive Force	248kN
Bucket Capacity	0.93m <sup>3</sup>
Boom Length	5.7m
Arm Length	2.9m
Track Gauge	2380mm
Track Length	4250mm

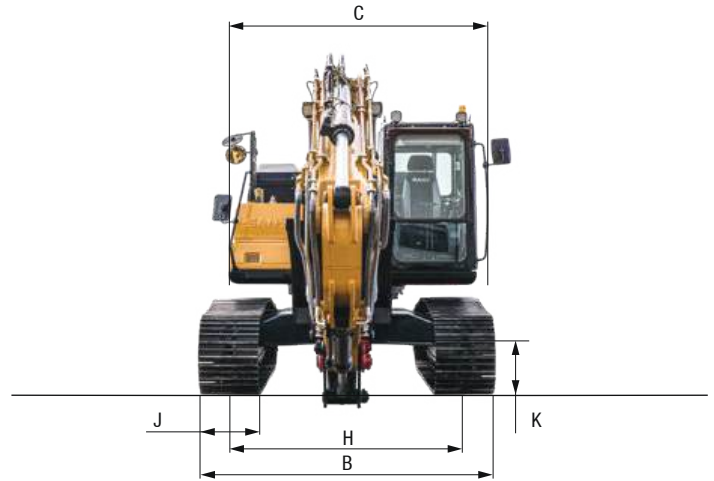

## LIFTING CAPACITIES\*

Load point height	Radius				Max. digging reach		m/ft					
	3.0m/9.8ft	4.5m/14.8ft	6.0m/19.7ft	7.5m/24.6ft	Capacity							
7.5 m kg			4319	4319	3736	3736	6.1					
24.6 ft lb			9522	9522	8236	8236	20.1					
6.0 m kg			4433	4433	3542	3542	7.2					
19.7 ft lb			9773	9773	7809	7809	23.8					
4.5 m kg			4973	4973	4774	3547	7.9					
14.8 ft lb			10964	10964	10525	7820	26.0					
3.0 m kg		7365	7279	5823	4790	4800	3445	8.3				
9.8 ft lb		16237	16047	12838	10560	10582	7595	27.1				
1.5 m kg		9085	6787	6476	4554	4660	3331	8.3				
4.9 ft lb		20029	14963	14277	10040	10274	7344	27.3				
Ground line	kg	6483	6483	9737	6526	6269	4388	4559	3248	4092	2845	8.1
	lb	14293	14293	21466	14387	13821	9674	10051	7161	9021	6272	26.6
-1.5 m kg		10665	10665	9632	6444	6200	4319	4532	3225	4453	3080	7.6
-4.9 ft lb		23512	23512	21235	14207	13609	9522	9991	7110	9817	6790	24.9
-3.0 m kg		14488	12609	9719	6509	6233	4358			5324	3662	6.7
-9.8 ft lb		31941	27798	21427	14350	13741	9608			11737	8073	22.1
-4.5 m kg		12167	12167	8569	6733					7760	5243	5.3
-14.8 ft lb		26824	26824	18891	14844					17108	11559	17.4

\*at 600 mm track pads width

# SPECIFICATIONS

## SANY SY215C

### DIMENSIONS

A	Transport length	9728 mm
B	Transport width*	2980 mm
C	Upperstructure carriage	2710 mm
D	Height over cabin/ROPS	2960 mm
E	Height of Boom – transport	3370 mm
F	Overall length of crawler	4450 mm
G	Tail length	2890 mm
H	Track gauge	2380 mm
I	Track height	923 mm
J	Track pads width	600 mm 700 mm 800 mm
K	Min. ground clearance	480 mm
L	Counterweight clearance	1090 mm
M	Engine cover height	2630 mm
N	Tail swing radius	2890 mm
O	Center distance of tumbler	3640 mm

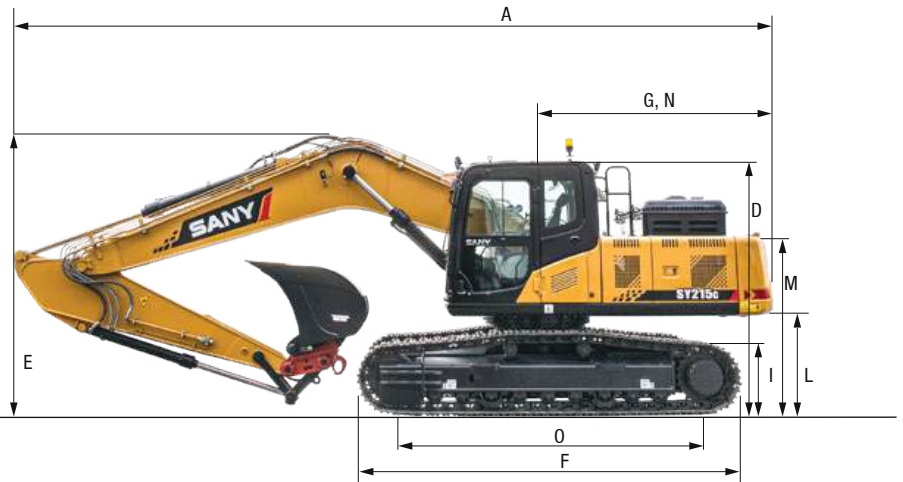

\*at 600 mm track pads width

### WORKING AREA

A	Max. digging reach	9950 mm
B	Max. digging depth	6600 mm
C	Max. digging Height	9570 mm
D	Max. dumping height	6700 mm
E	Min. dumping height	2470 mm
F	Max. vertical digging depth	5800 mm
G	Overall height over arm by min. swing radius	7680 mm
H	Min. swing radius	3730 mm

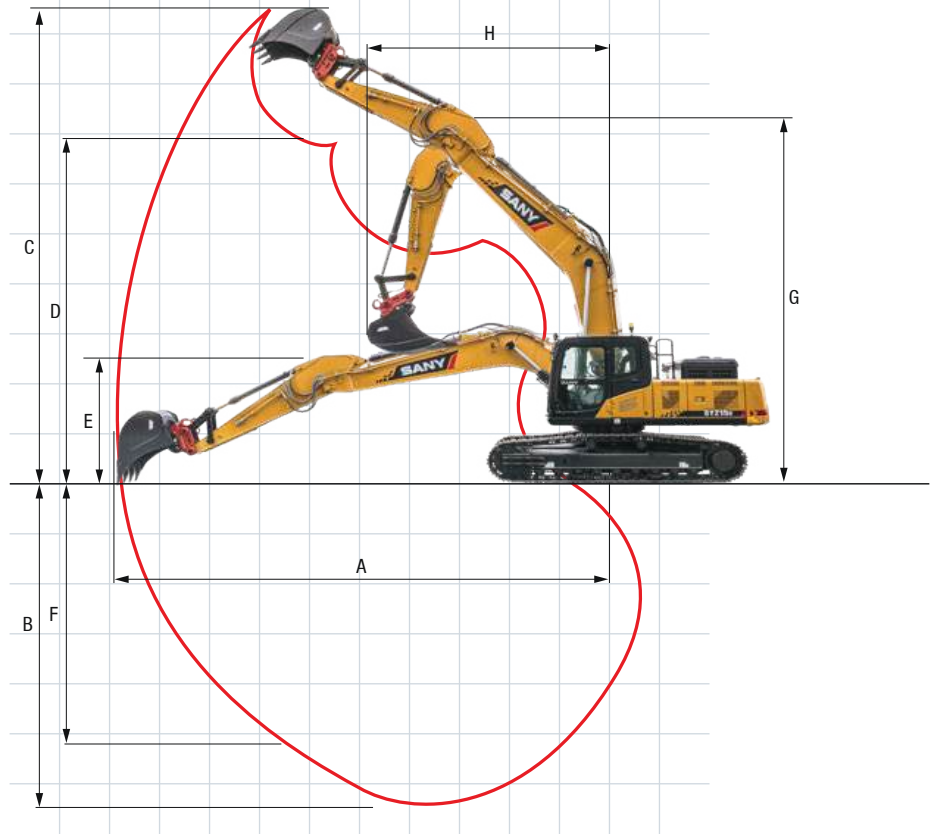



# SPECIALISED EQUIPMENT HIRE SOLUTIONS

## Branch Locations

### NSW/ACT

25-39 Chadderton Street,  
Cabramatta NSW 2166  
nswsales@prestonhire.com.au

### NSW

56 Sandringham Place,  
Thornton, NSW, 2322  
nswsales@prestonhire.com.au

### QLD

83 Parramatta Road,  
Underwood, QLD 4119  
qldsales@prestonhire.com.au

### VIC/TAS

38 Sunline Dr,  
Truganina, VIC 3029  
vicsales@prestonhire.com.au

### WA/NT

Unit 2,8 Hunt Street,  
Malaga, WA 6090  
wasales@prestonhire.com.au

### SA

102 Cormack Road,  
Wingfield, SA 5013  
sasales@prestonhire.com.au

*\*Preston Hire available across Oceania*



COUNT ON US

1800 440 550 | [prestonhire.com.au](http://prestonhire.com.au)