

MAEDA LC1385M



The Maeda LC1385M has a 18.0m five section telescopic boom, 6.0t capacity, highly compact tracked footprint with no need for outriggers and near zero-tail swing, making it ideal for use in tight areas. It boasts a super 2000kg "pick & carry" capability. Other features include a climatized enclosed cabin and a gross weight of 15,850kg. Consider the possibilities...

SPECIFICATIONS

MAEDA LC1385M

DIMENSIONS

Length	6545mm
Width	2490mm
Height	2965mm
Weight	15640kg or 15850kg (w/blade)

CAPACITY

Max. capacity	6000kg at 2.6m
Max. working radius (main boom)	430kg at 16.1m
Max. working radius (fly jib)	220kg at 16.7m
Max. lifting height (main boom)	16.7m
Max. lifting height (fly jib)	22.0m

TRACK

Width	500mm
-------	-------

MIN. TRANSPORT WIDTH

Overall Track	2490mm
Overall Unit	2490mm

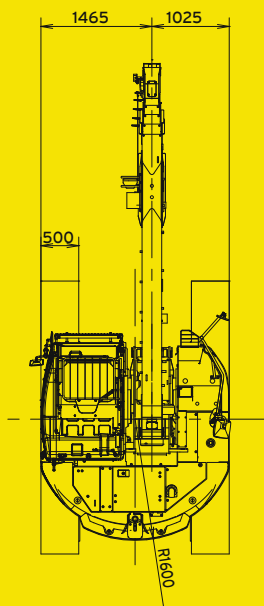

WORKING RANGE

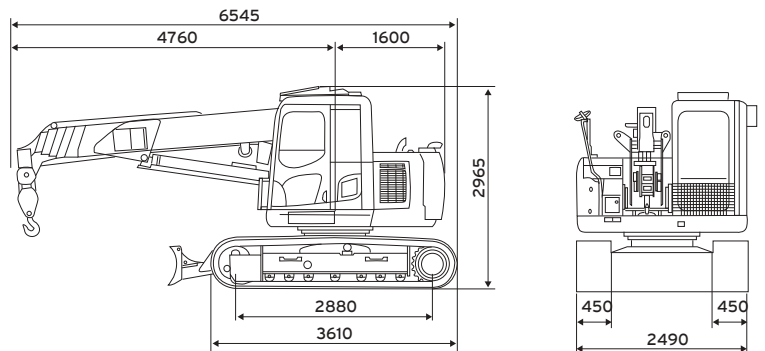
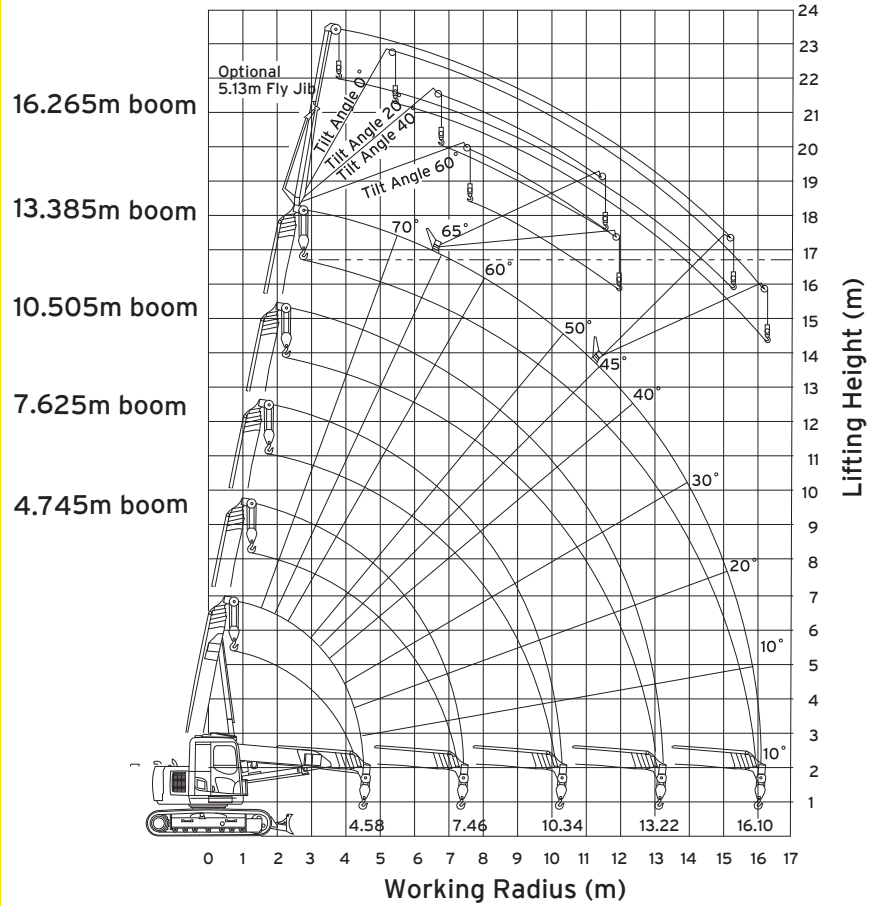

COUNT ON US

1800 440 550 | prestonhire.com.au

LOAD CHART

MAEDA LC1385M

LOAD CHART

4 Falls

TOTAL RATED LOAD										
	4.745m Boom		7.625m Boom		10.505m Boom		13.385m Boom		16.265m Boom	
Working Radius (m)	Total Rated Load (kg)		Total Rated Load (kg)		Total Rated Load (kg)		Total Rated Load (kg)		Total Rated Load (kg)	
	Stationary Travelling		Stationary Travelling		Stationary Travelling		Stationary Travelling		Stationary Travelling	
2.0	6000	2000	6000	2000	3000	1500				
2.5	6000	2000	6000	2000	3000	1500	3000	Unusable		
2.6	6000	2000	6000	2000	3000	1500	3000	Unusable		
3.0	5250	2000	5260	2000	3000	1500	3000	Unusable	2600	Unusable
4.0	3830	1915	3820	1910	3000	1500	3000	Unusable	2600	Unusable
4.5	3320	1660	3310	1655	3000	1500	3000	Unusable	2600	Unusable
5.0			2880	1440	2710	1355	2640	Unusable	2600	Unusable
6.0			2210	1105	2140	1070	2100	Unusable	2080	Unusable
7.0			1720	860	1720	860	1710	Unusable	1710	Unusable
8.0					1400	700	1430	Unusable	1430	Unusable
9.0					1150	575	1200	Unusable	1210	Unusable
10.0					940	470	1020	Unusable	1040	Unusable
11.0							880	Unusable	890	Unusable
12.0							750	Unusable	770	Unusable
13.0							650	Unusable	670	Unusable
14.0							Unusable	Unusable	580	Unusable
15.0							Unusable	Unusable	500	Unusable
16.0							Unusable	Unusable	440	Unusable
16.1							Unusable	Unusable	430	Unusable

The total rated load charts are based on the actual working radius including boom deflection.

Disclaimer. All information provided in this publication is correct at time of printing. Please contact Preston Hire for any updated versions.



SPECIALISED EQUIPMENT HIRE SOLUTIONS

Branch Locations

NSW/ACT

25-39 Chadderton Street,
Cabramatta NSW 2166
nswsales@prestonhire.com.au

NSW

56 Sandringham Place,
Thornton, NSW, 2322
nswsales@prestonhire.com.au

QLD

83 Parramatta Road,
Underwood, QLD 4119
qldsales@prestonhire.com.au

VIC/TAS

38 Sunline Dr,
Truganina, VIC 3029
vicsales@prestonhire.com.au

WA/NT

Unit 2,8 Hunt Street,
Malaga, WA 6090
wasales@prestonhire.com.au

SA

102 Cormack Road,
Wingfield, SA 5013
sasales@prestonhire.com.au

**Preston Hire available across Oceania*



COUNT ON US

1800 440 550 | prestonhire.com.au