

PLATFORM BASKET 3315

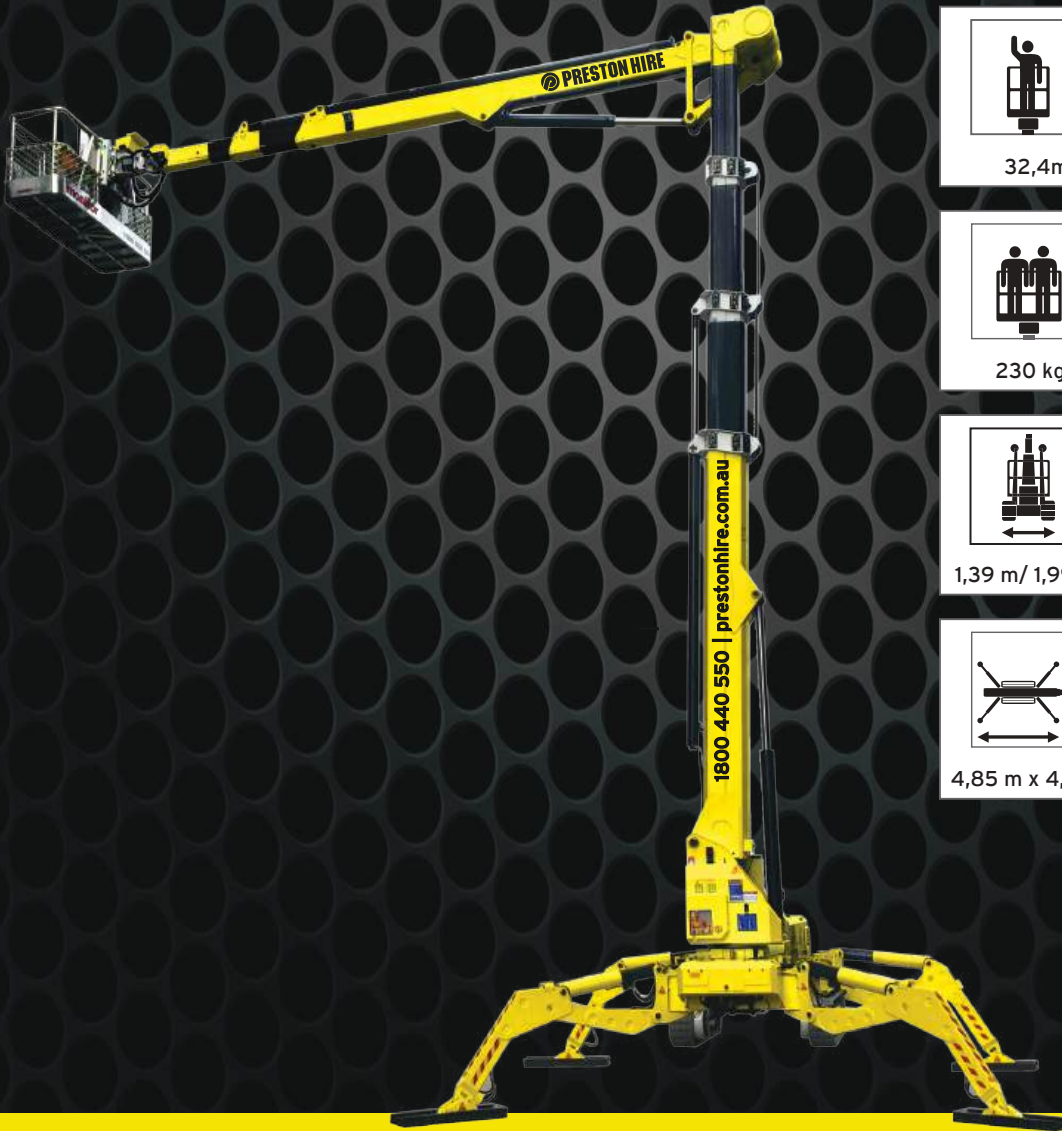

 32,4m	 13.7m
 230 kg	 max.7,09m min. 6,54m
 1,39 m/ 1,99 m	 6800kg
 4,85 m x 4,61 m	 KUBOTA Diesel Lithium Battery

The Platform Basket 33.15's unique telescoping articulated boom design provides exceptional up-and-over outreach capabilities. Dual position stabilizer legs allow the Platform Basket 33.15 to be set up in the most challenging locations. Even if a location only permits the stabilizers to be set in the narrow position, full outreach can still be achieved! This superstar spider lift is a true secret weapon within our SuperElevate range. Consider the possibilities..."

SPECIFICATIONS

PLATFORM BASKET 33.15

CAPACITY

Load **230kg**

SPECIFICATIONS

Working Working Height max. **32.4m**

Horizontal Working Outreach max. **14.7m**

Working Height max. **30.4m**

Total Weight **6800kg**

WORKING RANGE

Complies with AS1418.10
*137kN/m² with optional longer foot pads.

Max Horizontal Outreach to edge of basket (m)	14.7
Weight / Outreach Limited (Yes/No)	Yes
Turret Rotation	400°
Basket Rotation	180°
Length with basket (m)	7.13
Length w/out basket (m)	6.57
Width stowed (m) tracks retracted	1.39
Height (m) tracks retracted	1.99
Basket Dimensions	1.5 x 0.8 (2.2 x 0.8 option)
Total Weight (kg) (diesel and batteries)	6800
Max ground pressure driving (approx)	68.6kN/m ²
Max stabilizer force	46.7 kN
Max stabilizer pressure with std foot pad	520kN/m ² *
Gradeability length-wise	31 o/o / 17°
Gradeability sideways	31o/o / 17°
Stabilizer set-up dimensions	4.85 x 4.61 o/o
Narrow set-up dimensions	6.87 x 3.0
Max slope for stabilizers	15°
Stabilization system	Radio/auto
Optional Power Sources	24 Volt Battery System 240 Volt electric system
Stand Power Source/s	Kubota 22 HP Diesel
Drive system	Tracks
Expanding tracks	Std
Drive speed km/h	2.2
2 Speed Drive	Yes
Remote drive control	Radio Std
Battery voltage	12
Traction battery voltage	24/420A
Basket load control	Std
Electric & Air outlets in basket	Std
Electric emergency lowering	Std
Boom function	Radio control

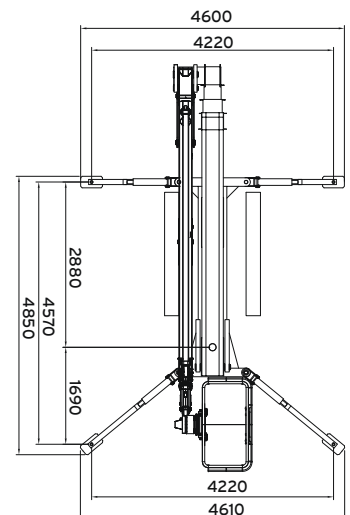
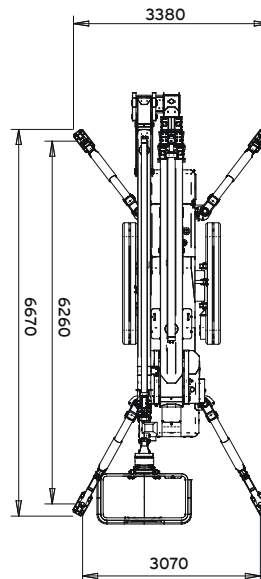
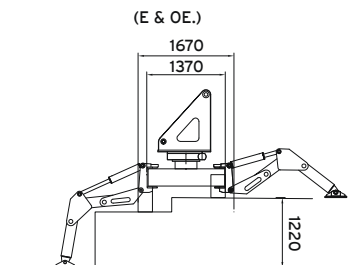
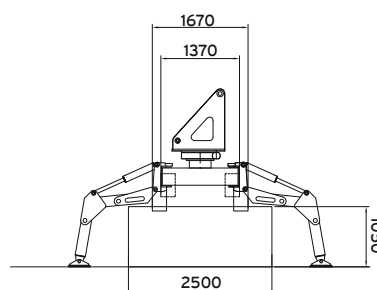
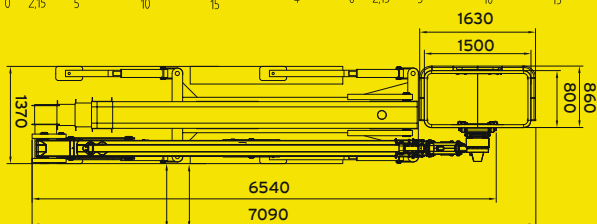
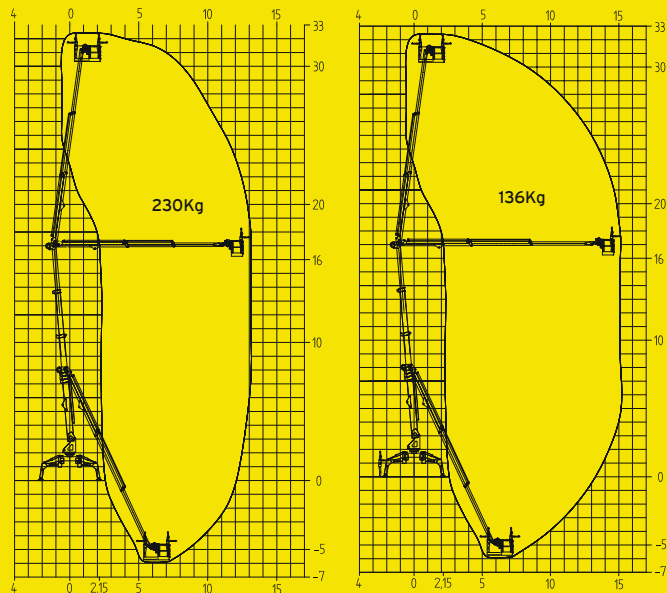

COUNT ON US

1800 440 550 | prestonhire.com.au



Perth

Adelaide

Sydney

Brisbane

Newcastle

Melbourne



SPECIALISED EQUIPMENT HIRE SOLUTIONS

Branch Locations

NSW/ACT

25-39 Chadderton Street,
Cabramatta NSW 2166
nswsales@prestonhire.com.au

NSW

56 Sandringham Place,
Thornton, NSW, 2322
nswsales@prestonhire.com.au

QLD

83 Parramatta Road,
Underwood, QLD 4119
qldsales@prestonhire.com.au

VIC/TAS

38 Sunline Dr,
Truganina, VIC 3029
vicsales@prestonhire.com.au

WA/NT

Unit 2,8 Hunt Street,
Malaga, WA 6090
wasales@prestonhire.com.au

SA

102 Cormack Road,
Wingfield, SA 5013
sasales@prestonhire.com.au

**Preston Hire available across Oceania*



COUNT ON US

1800 440 550 | prestonhire.com.au